

SKANTHERM SHAKER: INSTALLATION AND USER MANUAL

1. TECHNICAL DATA	2
2. PRE-INSTALLATION	3
3. INSTALLATION	5
4. OPERATION	9
5. TESTING	10

Keep for future use

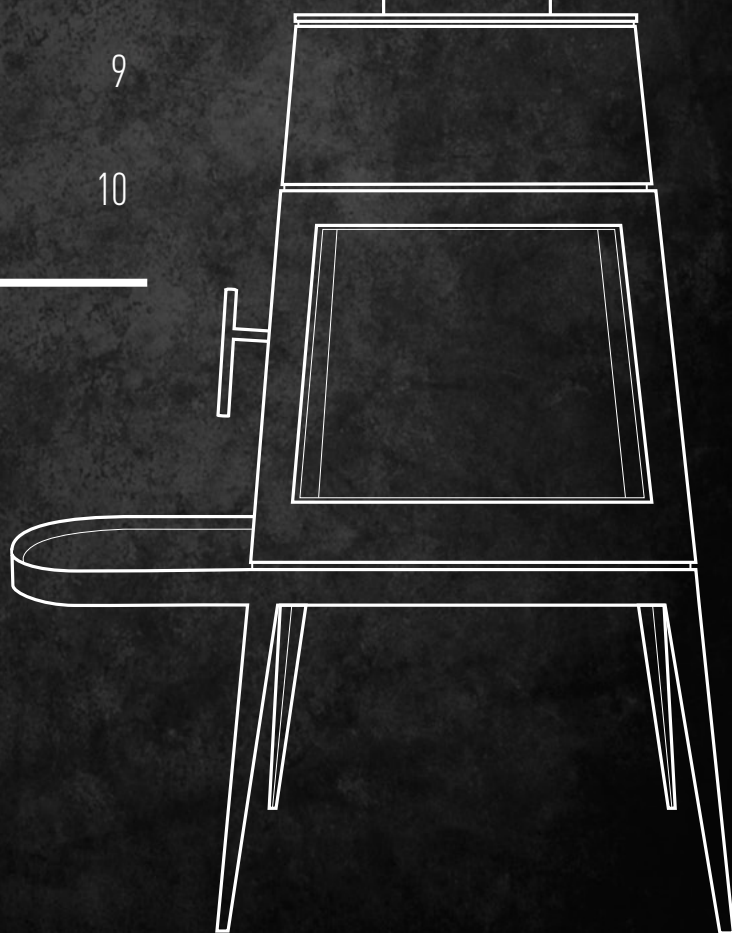

skantherm.
fireworks

oblica

OBLICA

200 Argyle St
Fitzroy VIC 3065
03 9416 0400

1. TECHNICAL DATA

WEIGHT AND DIMENSIONS:

Dimensions Firebox	W395 x H348 x D305mm
Firebox weight	112kg
Flue kit	Standard 6" / 8" / 10"

DETERMINED UNDER TEST CONDITIONS:

Nominal thermal output	7kW
Efficiency (Australian Test)	60%
Emissions (Australian Test)	1.2 g/Kg

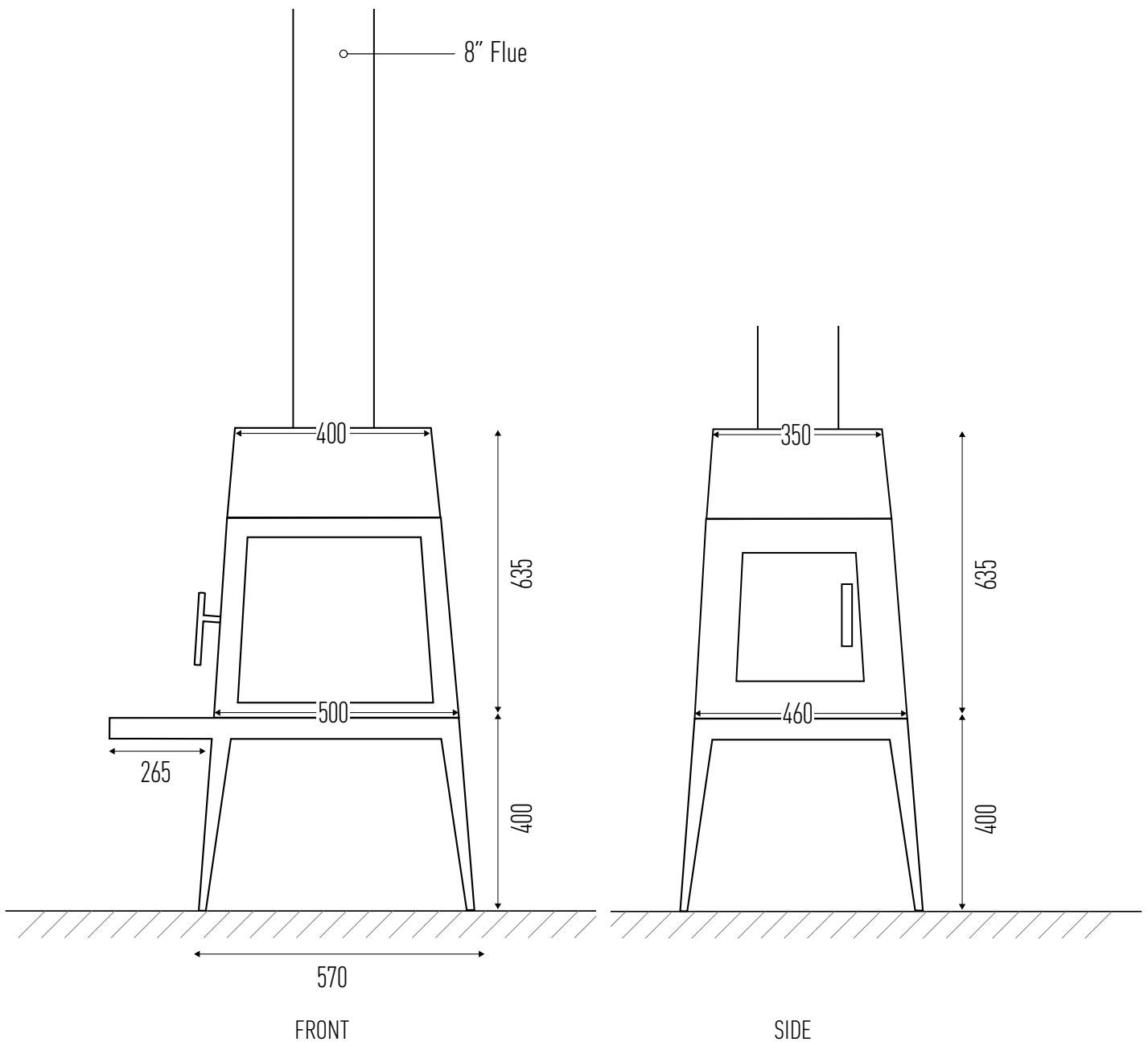

2. PRE-INSTALLATION

Congratulations on your purchase of the Shaker. This appliance should be installed and checked by a qualified professional. Ensure you have read the operation guidelines thoroughly prior to first use. For any questions or concerns please contact Oblica on 03 9416 0400.

The installation process is outlined below:

- Determine position of firebox and flue carefully observing the clearances described within this section
- Install the external flue
- Install the internal flue and engage the firebox
- Ensure the floor has adequate protection

CAUTION:

Using components or parts other than those provided by the manufacturer or modifying the specification of components may result in inferior or unsafe operation. If such action is necessary, consult the manufacturer in the first instance.

WARNING:

- The appliance and flue-system must be installed in accordance with AS/NZS 2918 and the relevant building code or codes.
- Any modification of the appliance that has not been approved in writing by the testing authority will be in breach of the approval granted for compliance with AS/NZS 4013.
- Once the flue has been installed and approved by a professional installer, the flue must not be modified in any way.

2. PRE-INSTALLATION (CONTINUED)

MINIMUM CLEARANCE — INTERNAL

2.1 Clearance from non-combustible surfaces (eg masonry)

100mm minimum clearance is required from fully non-combustible surfaces.

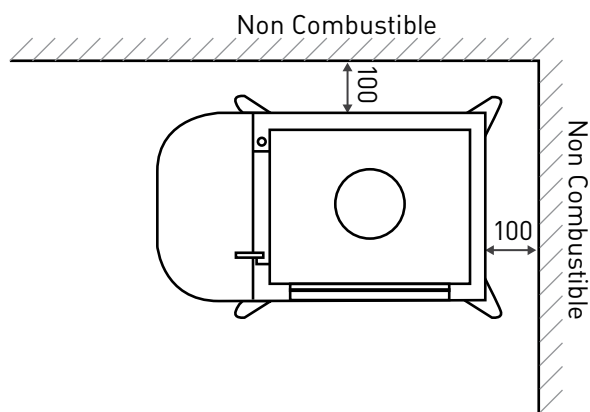

2.2 Clearance from glass

180mm minimum clearance is required from normal non-combustible glass.

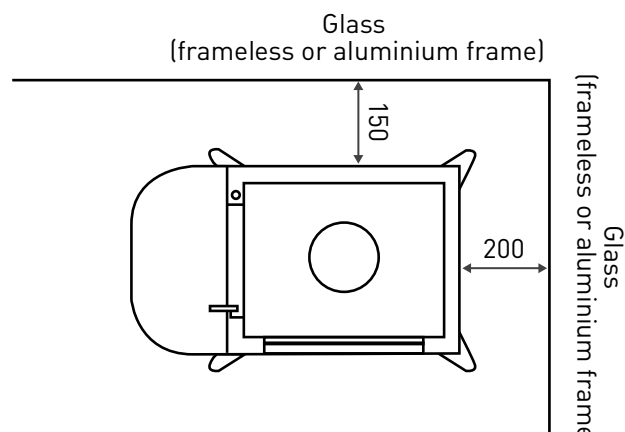

2.3 Clearance from combustible surfaces (eg timber joist & concrete)

Clearances may be reduced with the application of heat shielding to walls in accordance to the Australian Building Code.

For information on heat shielding please contact our office on 03 9416 0400 or email info@oblica.com.au.

Configuration 1 – Parallel installation

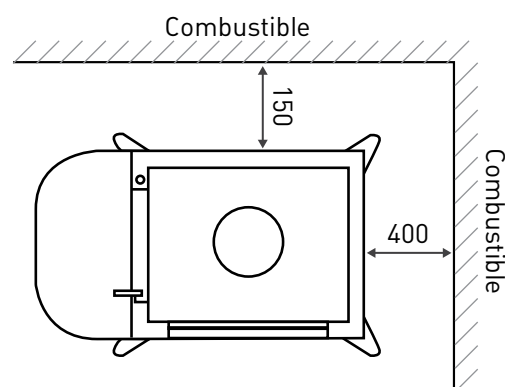

IMPORTANT:

Frames must also be considered. Timber window frames must be treated as combustible surfaces (see 2.3). Aluminium frames can be treated as non-combustible surfaces (see 2.2).

3. INSTALLATION

3.1 Installing flue kit

Ensure flue is installed as per Australian standards (see the following diagrams below).

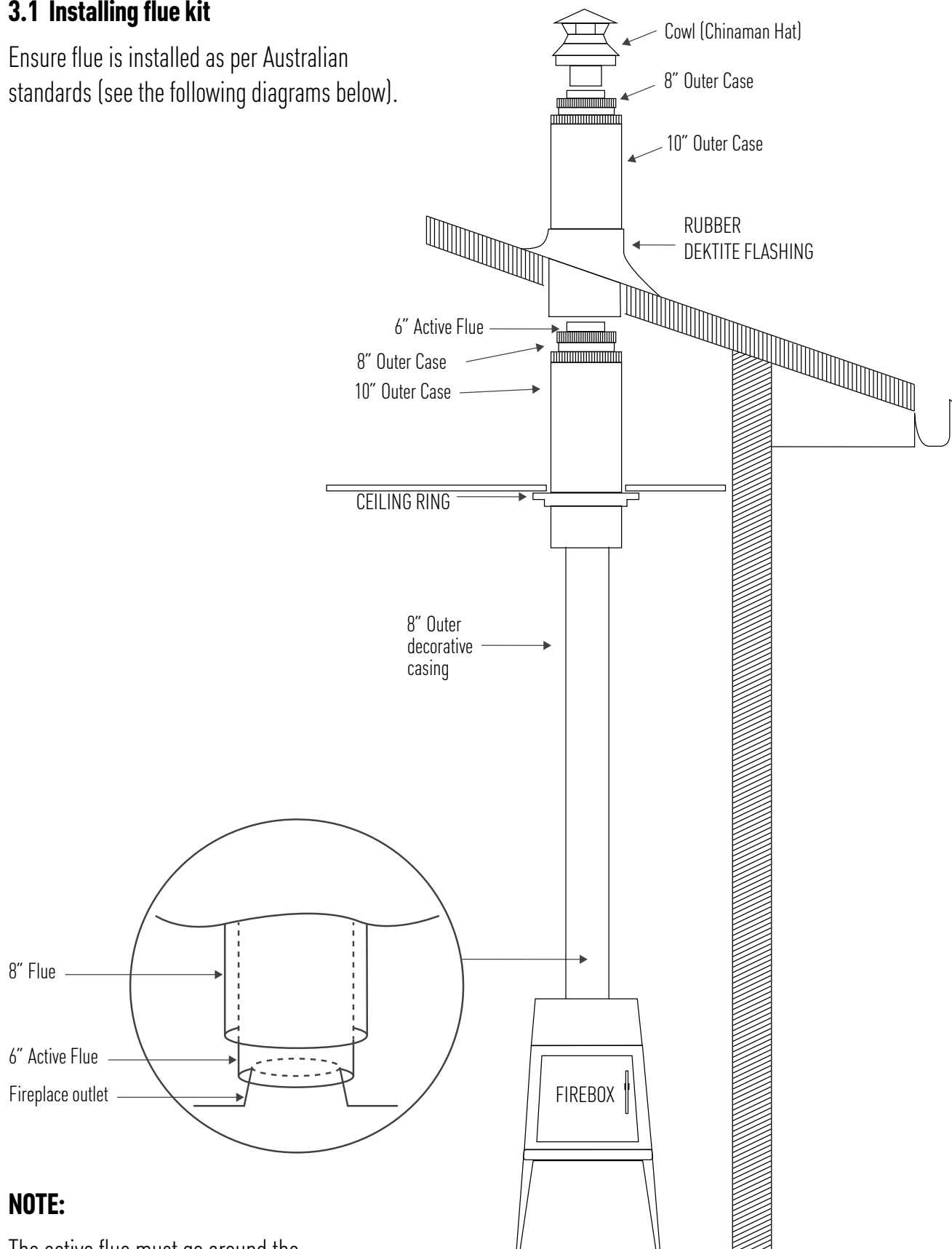

NOTE:

The active flue must go around the fireplace outlet on the outside.

3. INSTALLATION (CONTINUED)

PITCHED ROOF INSTALLATION

The top of the flue must be 400mm higher than the highest point of the roof. Alternatively, there must be a minimum distance of 3 meters from any higher section of roof.

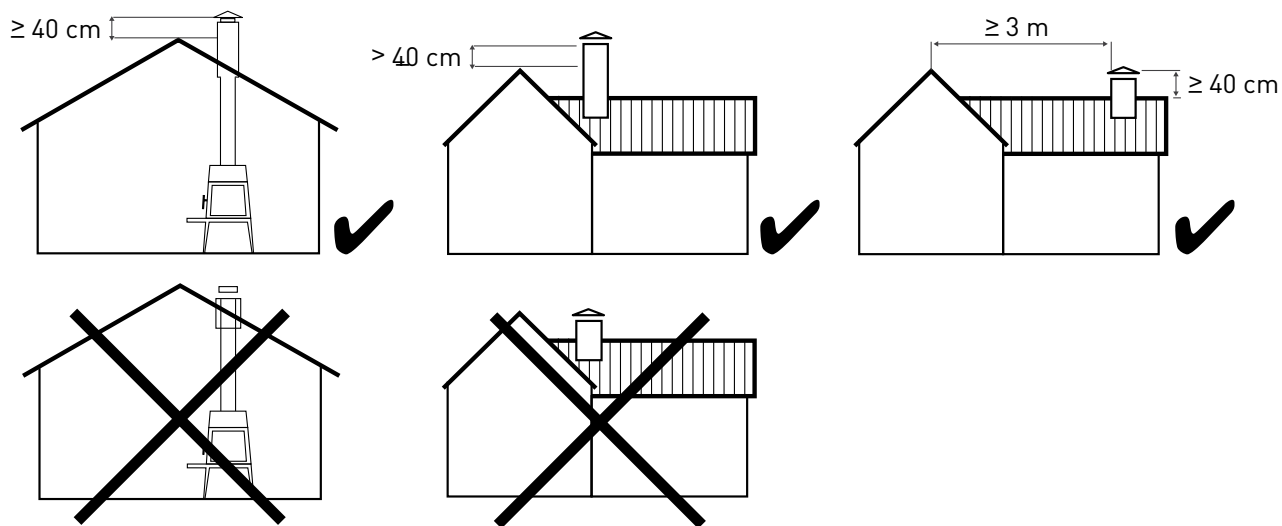

FLAT ROOF INSTALLATION (LESS THAN 5° PITCH)

The top of the flue must be 900mm above the roofline. Alternatively, there must be a minimum distance of 3 meters from any higher section of roof.

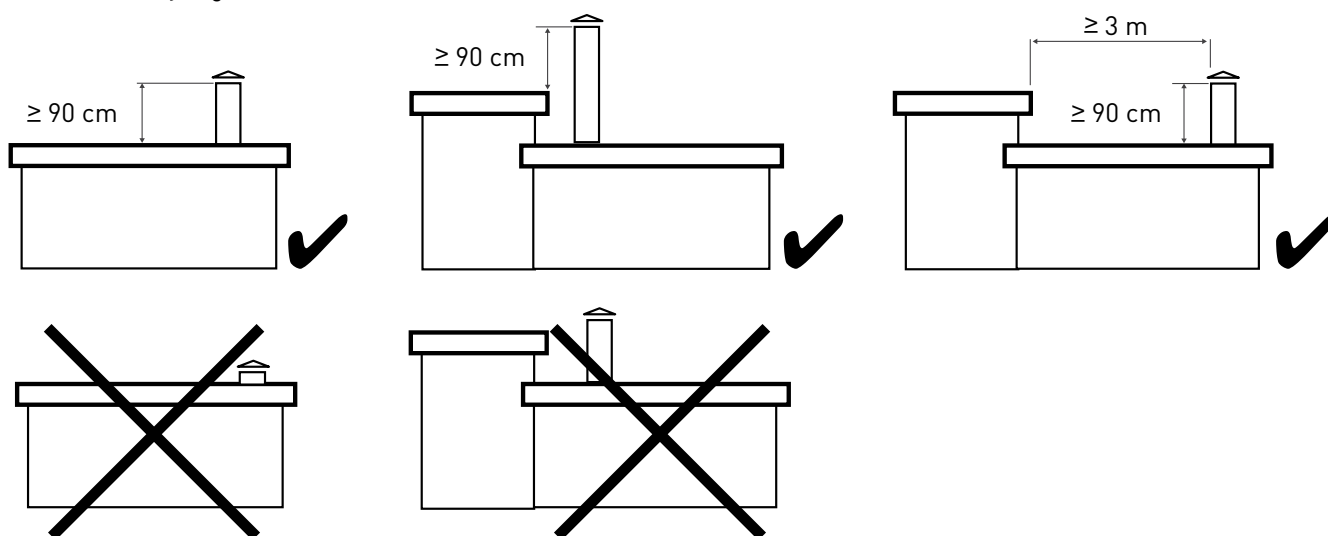

3. INSTALLATION (CONTINUED)

3.2 Protecting the floor

- Any combustible floor beneath a fireplace must have a floor protector that extends 300mm at the front of the opening door.
- If installed directly on combustible material, the floor protector must be made of a minimum 6mm thick cement sheet. Non-combustible finishes can be applied to the floor protector (tiles, steel sheet, light concrete, etc).
- If the combustible floor is installed on concrete, you can replace the combustible material with non-combustible material laid directly onto the concrete.

FLOOR PROTECTOR LAID ON TIMBER FLOOR

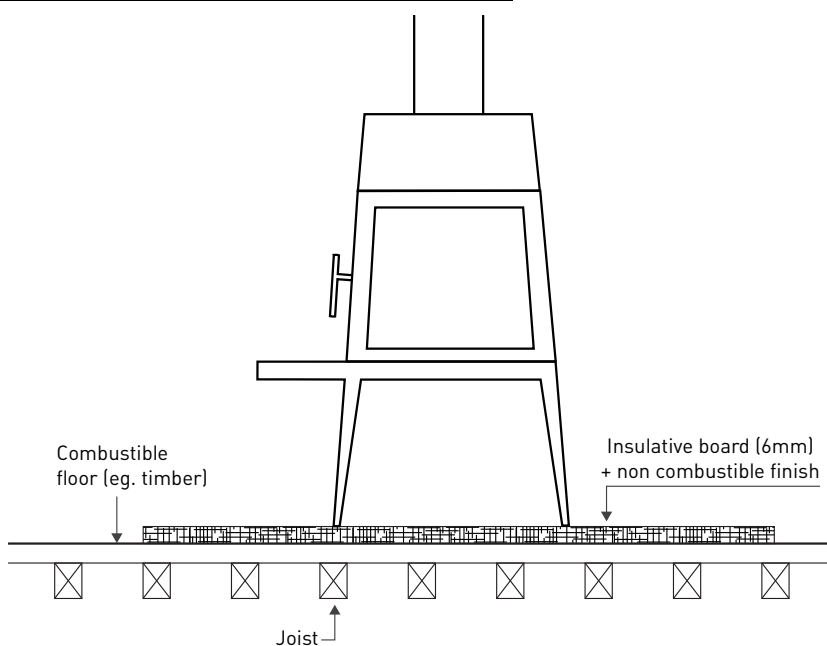

FLOOR PROTECTOR LAID ON JOIST

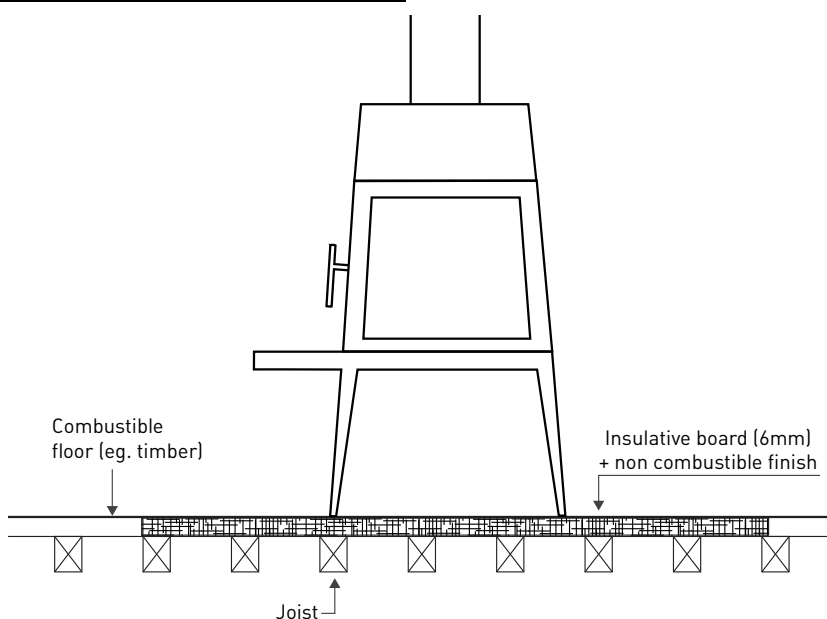

3. INSTALLATION (CONTINUED)

FLOOR PROTECTOR LAID ON CONCRETE

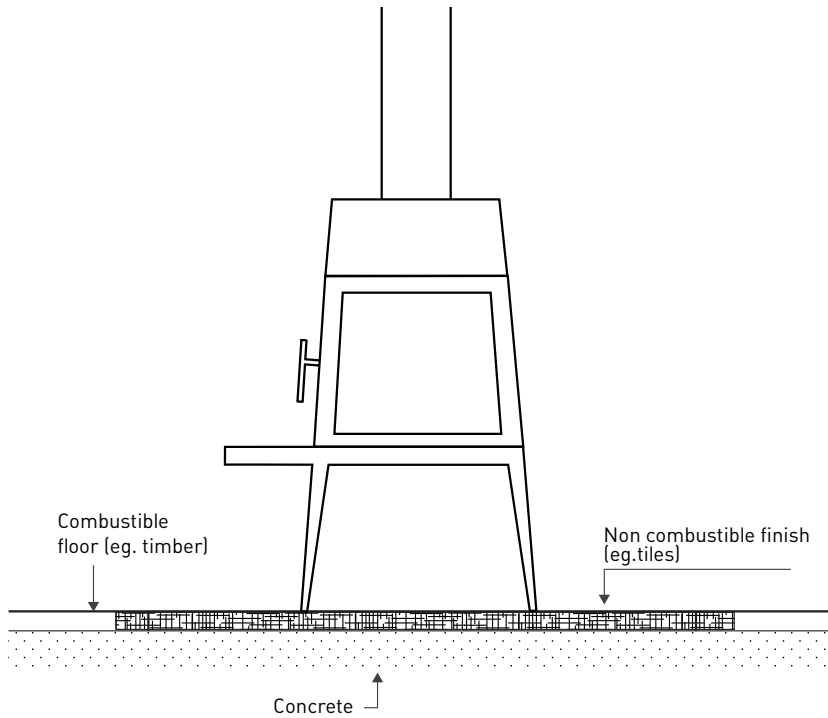

TOP VIEW

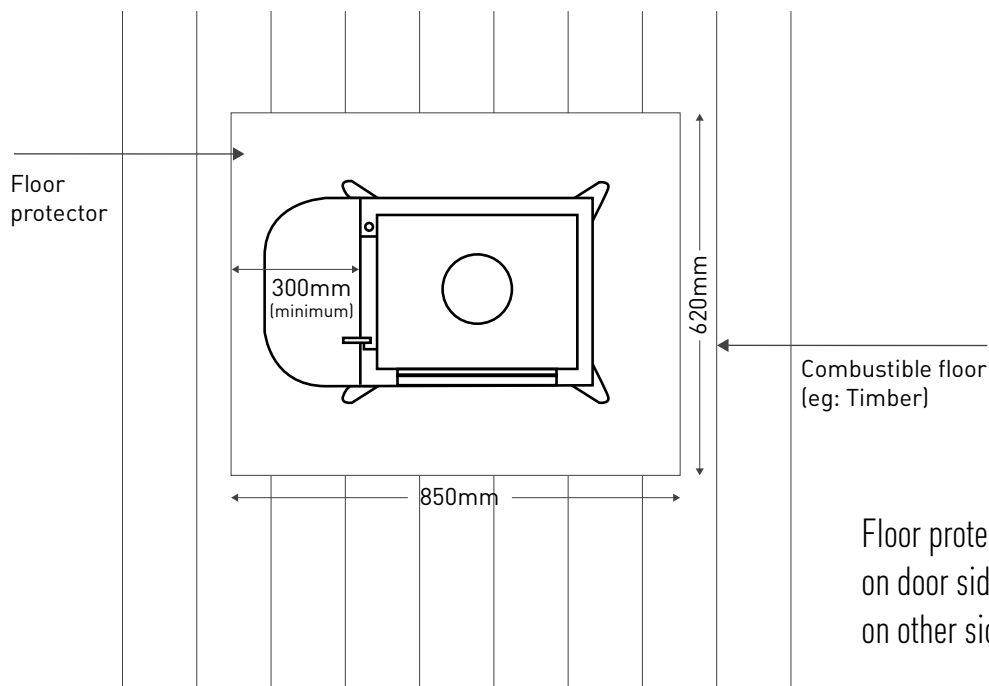

4. OPERATION

4.1 What you should burn

- Untreated, air dried hardwood
- Split logs with a humidity content of less than 20%

4.2 Do not burn

- Trash
- Painted plastic
- Coated or preservative treated wood
- Waste or black coal
- Inflammable liquids
- Fire gels
- Moist wood with a residual humidity content of more than 20% (this may cause sooting of the chimney).

IMPORTANT:

- Misuse may lead to unhealthy and environmentally harmful emissions and will void any warranty or guarantee.
- The maximum load capacity for the Shaker is 10kg of wood.
- Burning only seasoned hardwood helps to protect the environment and lower emissions.

For details of a wood supplier in your area please call our office on 03 9416 0400 or email info@oblica.com.au.

WARNING:

- Do not use flammable liquids or aerosols to start or rekindle the fire.
- Do not use flammable liquids or aerosols in the vicinity of the fireplace when operating.
- Do not store fuel within prescribed installation clearance distances.
- The use of some types of preservative-treated woods as a fuel can be hazardous.

5. TESTING

TEST REPORT NO	ASFT20093
TESTING LABORATORY:	AUSTRALIAN SOLID FUEL TESTING 3 Garden st, Morwell VIC 3840
MANUFACTURER:	Skatherm GMBH
MODEL:	Shaker fireplace
WORK REQUESTED:	The Shaker Free-Standing solid fuel appliance was tested for particulate emissions power output and efficiency according to the requirements of the joint Australian/New Zealand Standard AS/NZS 4012/4013 (2014)
TEST DATES:	1 October 2020
INVESTIGATING OFFICERS:	Steve Marland
RESULTS:	The appliance particulate emissions factor was 1.2g/kg of hardwood that complies to AS/NZS 4014.1, and the average efficiency of the appliance for all burn rates was 60%
CONCLUSION:	The Shaker Free-Standing solid fuel appliance complies with the requirements of AS/NZS 4012/4013 (2014)